

## 2\_2 TENSILE LANDSCAPE

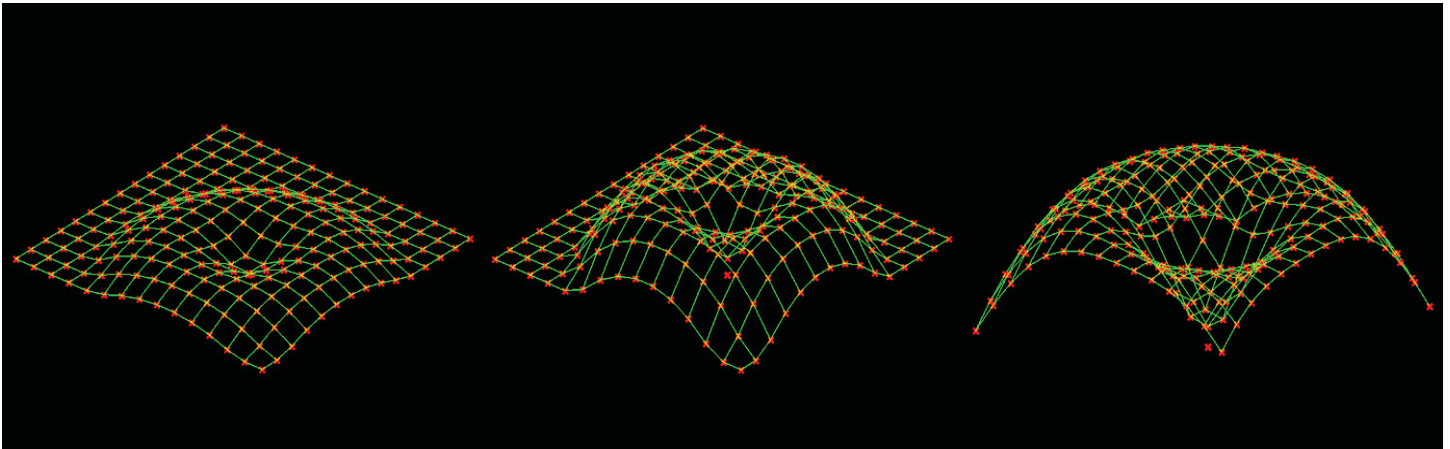

### Step1 : Setting up the Point Grid

1. **Slider** x 3 (Params/Special/Number Slider)
  - "Grid Distance" : Floating point, Lower limit=0, Upper limit=3.0, Value=1.0
  - "X-GRID" : Integers, Lower limit=0, Upper limit=20, Value=15
  - "Y-GRID" : Integers, Lower limit=0, Upper limit=20, Value=15

#### 2. **SqGrid**

- P : default
- S : "Grid Distance"
- Ex : "X-GRID"
- Ey : "Y-GRID"

#### 3. **Point** (Params/Geometry/Point) : "Grid Pts"

- SqGrid(P)

#### 4. **Point** (Params/Geometry/Point) : "Flat Pts"

- Point("Grid Pts")

#### 5. **Point** (Params/Geometry/Point) : "Attractor"

- Draw one point in Rhino scene
- Right-click and select 'Set one Point' and select the point in Rhino scene

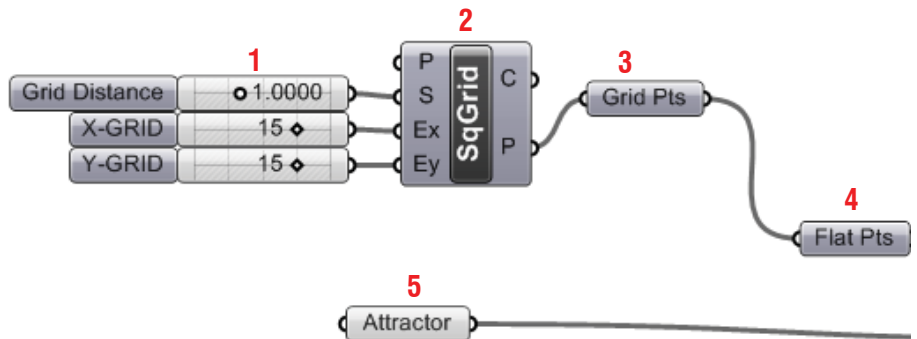

### Step2 : Setting up Distance Parameter

#### 6. **Dist** (Vector/Point/Distance)

- A : Point("Flat Pts") to A
- B : Point("Attractor") to B

#### 7. **Slider** (Params/Special/Number Slider)

- "Range" : Floating point, Lower limit=0, Upper limit=50, Value=12.07

#### 8. **Division** (Scalar/Operator/Division)

- A : Distance
- B : Slider ("Range")

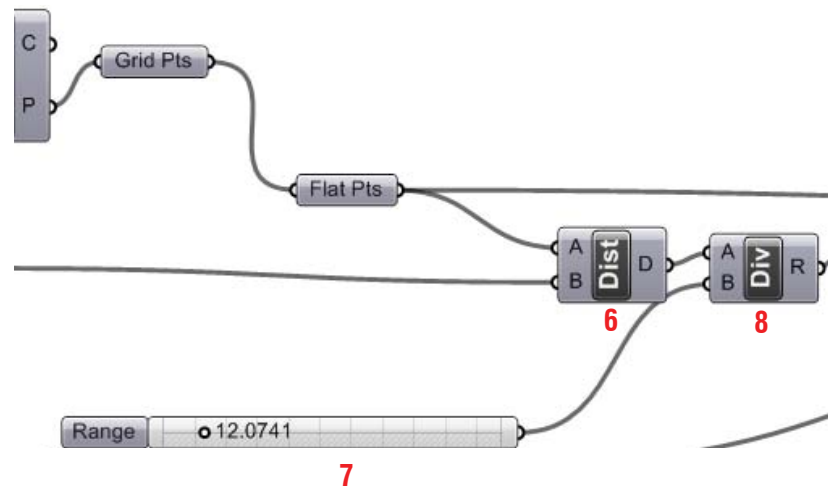

**Step3 : Geometry Deformation Fuction**

\*  $y = A \sin ( B \pi x )$  (*y:output, x:parameter, A:amplifier, B:range*)

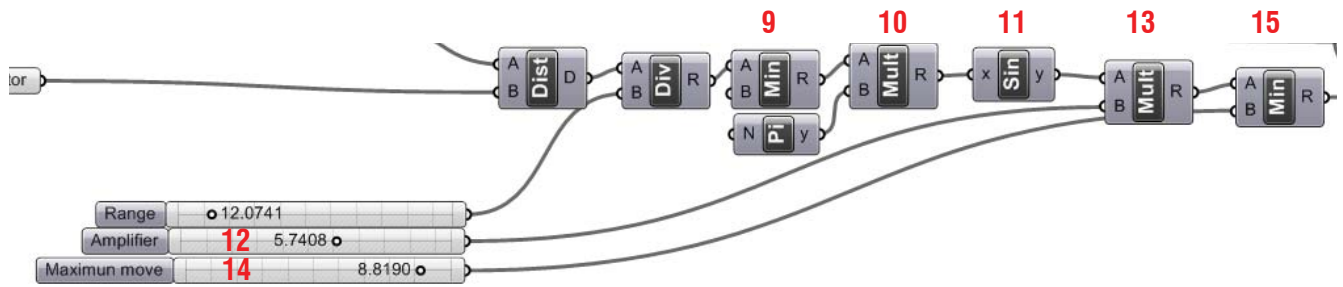

9. **Min** (Scalar/Util/Minimum)

- A : *Div*(R)

- B : Right Click and set Number : 1.0

\* *The reason to set this component is to limit the deformation value within 0~π on Sine function graph*

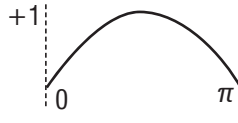

10. **Mult** (Scalar/Operator/Multiply)

- A : *Min*(R)

- B : *Pi*(Scalar/Constants/Pi)

11. **Sin** (Scalar/Trig/Sine)

- x : *Mult*(R)

12. **Slider** (Params/Special/Number Slider)

- "Amplifier" : Floating point,

Lower limit=0, Upper limit=5, Value=5.74

13. **Mult** (Scalar/Operator/Multiply)

- A : *Sin*(y)

- B : *Slider*("Amplifier")

14. **Slider** (Params/Special/Number Slider)

- "Maximum Move" : Floating point,

Lower limit=0, Upper limit=10, Value=8.81

15. **Min** (Scalar/Util/Minimum)

- A : *Mult*(R)

- B : *Slider* ("Maximum Move")

\* *This is for preventing from overflow of point movements*

**Step4 : Points Movement**

16. **Z** (Vector/Constants/Unit Z)

- Right click and set Number : -1 (Concaved)

or Right click and set Number : +1 (Convexed)

17. **Amp** (Vector/Vector/Amplitude)

- V : *Z*(V)

- A : *Min*(R)

18. **Move** (Xform/Euclidian/Move)

- G : *Point*("Flat Pts")

- I : *Amp*(V)

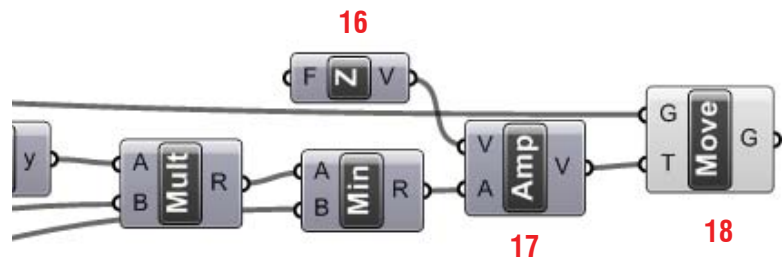

- The End -

Appendix

- Definition map

